



BRDR. CHRISTENSEN ApS

Skuderløse - DK 4690 Haslev - Tel. +45 56 36 36 36- Fax +45 56 36 36 00 – bch@bch.dk – www.bch.dk

SEGURO

A RUBBER SEALED GATE VALVE

Technical Information

The Seguro valve represents a well proven concept in gate valve design, it is unique in that the sealing of the gate valve is effected by a soft rubber seal, firmly secured by a special wedge.

The wedge is guided by grooves, cast into the valve body. Because the Seguro has no seat rings in the body, a smooth full bore is achieved. This, plus the self flushing design of the valve body, eliminates possible build-up of sediments or other foreign matter in the valve body. The result is a minimum of maintenance and 100% tight closure.

The packing gland has been replaced with a double o-ring seal embedded in nylon. Valves with rising stem uses U-packings in a brass bushing. This design assures positive seal at the stem and minimizes maintenance.

The above features, combined with simple but sound engineering practices, assure an ideal shut-off valve for almost all installations and media. Thus resulting in 100% closure, high reliability in service and long life with a minimum of maintenance, makes the Seguro a logical choice for economical and trouble free service.

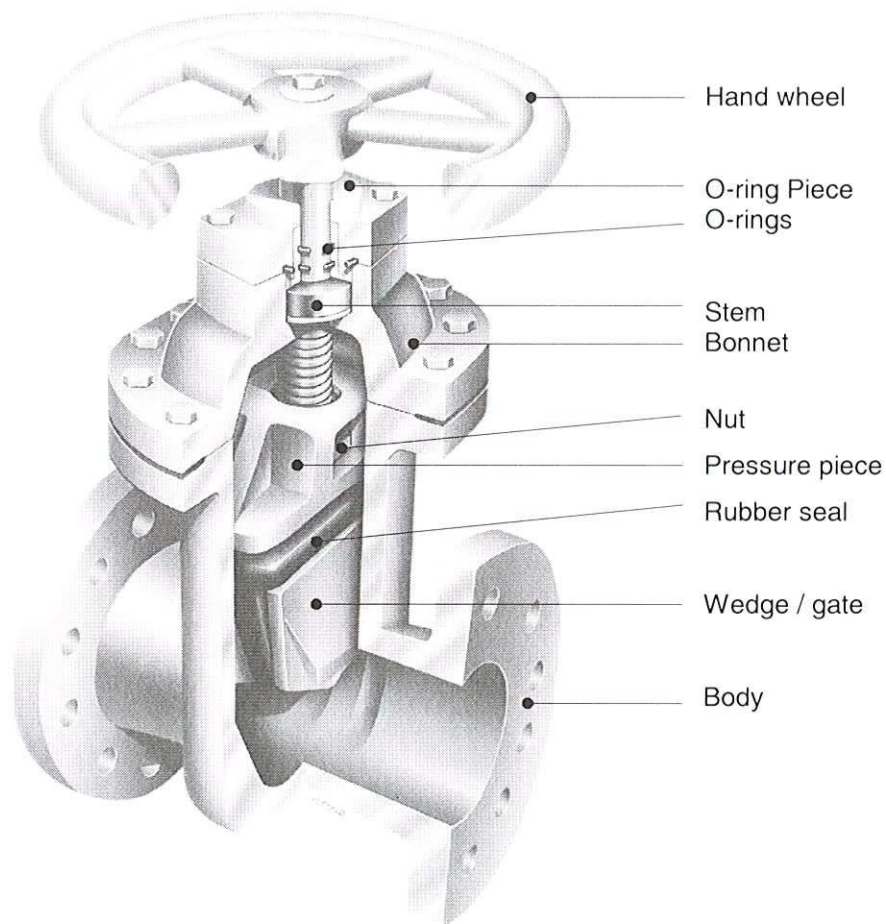

An extensive manufacturing program has made the Seguro valve an ideal choice for your particular application.

Manufacturing standards:	American, British, German
Pressure classes:	125, 250 (cast iron and ductile iron).
Body and bonnet:	Cast iron and ductile iron
Trim:	Seals: Nitrile butadien rubber (NBR), or EPDM. Stem: Stainless steel Nut: Brass or cast iron
Bonnet bolting	Hot galvanised or stainless steel
Operating methods:	Hand wheel, bevel or spur gear, electric, pneumatic or hydraulic cylinder

How to inquire for or order SEGURO GATE VALVES

Seguro Gate Valves are available in a wide range of variants, each having its own Identification number consisting of numerals and letters.

From the following page, please select the appropriate numerals and letters depicting the following:

- Standard
- End connection
- Pressure class
- Body and bonnet material
- Seal material
- Method of operation

Having selected the figure numbers required, simply state:

- Quantities
- Sizes
- Application (medium)
- Position (vertical/horizontal)
- Working pressure and temperature
- Placement and type of actuator, if any
- Special designs and requests, if any

Symbol:

Valve types for product group 12		1.	2.	3.	4.	5.	6.
Standard	American British German, short, EN 558-1 Series 14 German, long, EN 558-1 Series 15	A B TF TO					
End connection	Flanged Mechanical Joint Ends Victaulic Ends		1 4 6				
Pressure class	Class 125 or PN 10 PN 16 Class 250 or PN 25			1 2 3			
Body and bonnet material	Grey Cast Iron Ductile Iron				1 3		
Seal material	Nitrile Butadien Rubber E.P.D.M.					1 2	
Methods of Operating	Non Rising Stem:With operating square, without hand wheel Non Rising Stem:Complete with hand wheel Non Rising Stem:With indicator and hand wheel Non Rising Stem:With flange for mounting of multiturn actuator Non Rising Stem:With electric operator Non Rising Stem:With bevel gear and hand wheel Non Rising Stem:With bevel gear and flange for multiturn actuator Non Rising Stem:With spur gear and hand wheel Non Rising Stem:With spur gear and flange for multiturn actuator Rising Stem: (O.S. & Y.) Without hand wheel Rising Stem: (O.S. & Y.) Complete with hand wheel Rising Stem: With manual bevel gear operator Rising Stem: With flange for multiturn actuator						A AH AHI AL AE AM AML AT ATL B BH BM BL

In addition to the above designs, Seguro valves can be supplied with bypass in side or bottom, wheel support for horizontal mounting, and other. Please ask us!

Example: 12 - A 1 1 1 1 AH

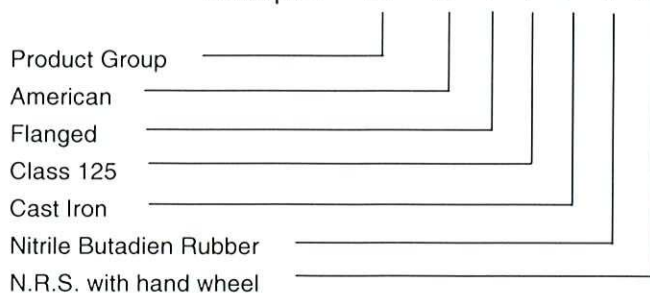

Index

Section A Choosing the right valve

Description of the Seguro gate valve	A1
How to order	A2
Valve types for product group 12	A3
Index	A4
Description of design details	A5
Special designs and service	A8
Accessories	A9

Section B American style valves

12-A11xx-A-AH-AM-AT Class 125 with flanges. Manual, NRS	B1
12-A11xx-AL Class 125 with flanges. For actuator, NRS	B2
12-A11xx-BH-BM-BT Class 125 with flanges. Manual, OS&Y	B3*
12-A11xx-BL Class 125 with flanges. For actuator, OS&Y	B4*
12-A41xx-A-AH-AM-AT Class 125, Mechanical joint. Manual, NRS	B5*
12-A41xx-AL Class 125, Mechanical Joint. For actuator, NRS,	B6*
12-A13xx-A-AH-AM-AT Class 250 with flanges. Manual, NRS	B7*
12-A13xx-AL Class 250 with flanges. For actuator, NRS	B8*

Section C German style valves

12-TF11xx-AH-AM-AT PN 10 short, with flanges. Manual, NRS	C1
12-TF11xx-AL PN 10 short, with flanges. For actuator, NRS	C2
12-TF11xx-BH-BM-BT PN 10 short, with flanges. Manual, OS&Y,	C3*
12-TF11xx-BL PN 10 short, with flanges. For actuator, OS&Y	C4*
12-TF12xx-AH-AM-AT PN 16 short, with flanges. Manual, NRS	C5
12-TF12xx-AL PN 16 short, with flanges. For actuator	C6
12-TF13xx-AH-AM-AT PN 16 short, with flanges. Manual, NRS	C7*
12-TF13xx-AL PN 16 short, with flanges. For actuator	C8*

Section D Appendix

Sectional drawings and parts list

Small valves, hand operated, Non Rising Stem	D1
Small valves, for actuator, Non Rising Stem	D2
Large valves, for actuator, Non Rising Stem	D3
Hand operated valves, Outside Stem and Yoke	D4

*) These catalogue sheets are not yet published.

Description of design details

Valve body

The body has no seat rings or recesses: The resulting 100% round bore keeps pressure drop to a minimum and prevents accumulation of sediments etc, that could affect the smooth operation and sealing of the valve. (Fig. 1)

Fig. 1

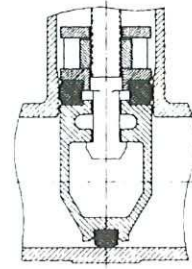

Smooth and accurate travel of the wedge assured by tongue type guides cast integrally with the wedge. These guides travel in grooves, cast into the valve body, ensuring smooth, accurate seating of the valve regardless of mounting position. (Fig 2)

Fig. 2

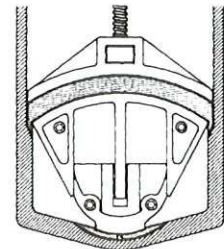

Bonnet

The bonnet in all sizes of Seguro valves are of the bolted construction (see fig. 3). As standard, hot galvanised bolts are used, but other materials can be delivered. (Fig. 3)

Fig. 3

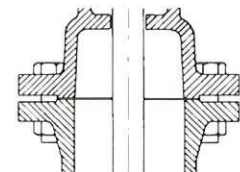

Non rising stem details

The following are valid up to and including DN 36" / DN 900mm.

The bearing assembly consists of a flanged cast iron or steel O-ring piece fastened to the bonnet with four bolts. The O-ring piece is bored and lined with a PA6 (nylon) bushing, into which two O-rings are inserted. (Fig. 4)

Fig. 4

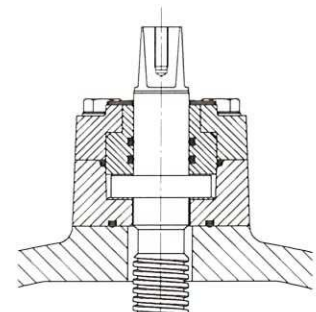

The stem is of one-piece construction with a very sturdy collar. Underneath the collar a PTFE washer is placed under; this is intended to ease operation of the valve, and, at the same time, to act as a seal between the spindle collar and the bonnet.

When the valve is fully open, the stem collar is pressed against the PTFE washer, thus sealing the valve. This facilitates the replacement of the O-rings with the valve under pressure. This is accomplished simply by removing the hand wheel and the four bolts in the O-ring piece.

As standard, valves for direct hand operating has a pyramid stem top, while stems for valves with gearbox or actuator has a cylindrical stem end and a flange according to ISO 5210

All NRS Seguro valves with hand wheel or operating square are equipped with a rubber disk fitted over the stem, flush with the O-ring piece. This prevents penetration of sediments or other foreign matter. (Fig. 5)

Fig. 5

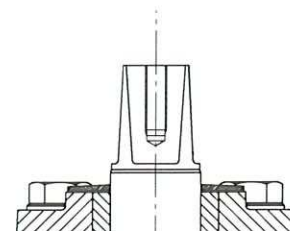

Refer to page D3 for details on stem bearing and seal for large valves.

SEGURO

A RUBBER SEALED GATE VALVE

Technical Information

Rising stem valves with outside stem and yoke (OS & Y)

On these valves the stem passage are designed as follows:

A brass bushing, which serves as a guide for the stem, is pressed into lower end of the yoke. This bushing is machined to contain the stem packing. (Fig 6)

The stem seal is a self-tightening U-cup seal, and is secured by a stainless steel locking ring. The yoke is bolted to the bonnet on all sizes.

The stem thread used are trapezoid.

If the valve is with hand wheel, this is mounted on a brass nut at the top of the yoke. This nut are kept in place by two ring-nuts, one over the hand wheel and one inside the yoke opening.

In case of an actuator or a reduction gear is uses, the thread is cut in the insert bushing of the actuator. The yoke will then be equipped with a standard flange (ISO 5210) at the top.

Fig. 6

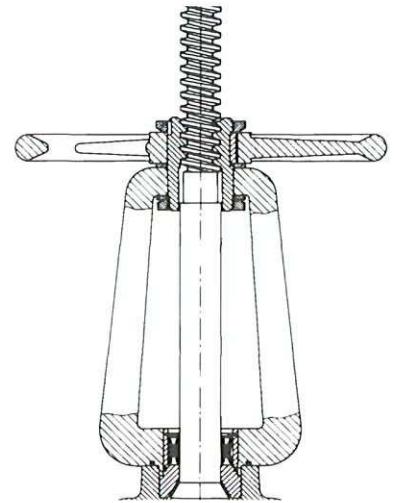

Stem nut

The standard material is brass, but the nut is also available in bronze or cast iron for improved corrosion resistance. The stem nut is loosely fitted into the pressure piece to prevent radial load of the stem. (Fig 7)

In the valves with OS&Y, a screw in the stem nut prevents the stem from rotating

Fig. 7

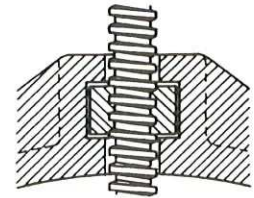

Wedge

The wedge (or gate) consist of half shells (bolted together with stainless steel bolts), a pressure piece and the rubber seal.

When assembled, the two halves and the pressure piece form a groove in which the rubber seal is retained and protected.

Projections are cast on the bottom of the wedge, these act as a stop and prevent overloading of the rubber seal. The valve cannot be over seated. A drain hole is provided in the bottom of the seal to prevent stagnation of water. (Fig 8)

The wedge is shown as it is about to be seated. Note that the seal touches the bottom of the port area as well as the vertical walls of the valve body, there are no projections. (Fig. 9)

The valve is now fully seated and closed tight. Note that the seal is firmly pressed against the bottom of the valve passage, and the pressure piece has forced the seal radial outward, effectively sealing the vertical walls of the valve. (Fig. 10)

Fig. 8

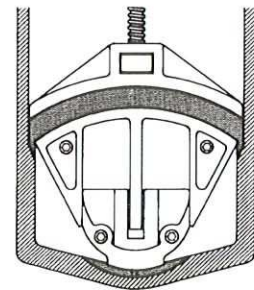

Fig. 9

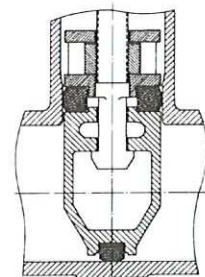
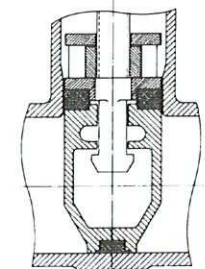

Fig. 10



SEGURO

A RUBBER SEALED GATE VALVE

Technical Information

Lifting lugs

The smaller Seguro valves up to DN 700 (28") are equipped with ring nuts for lifting the valve under installation, while the larger valves (from DN 800/30") have cast lifting lugs and tall bonnets.

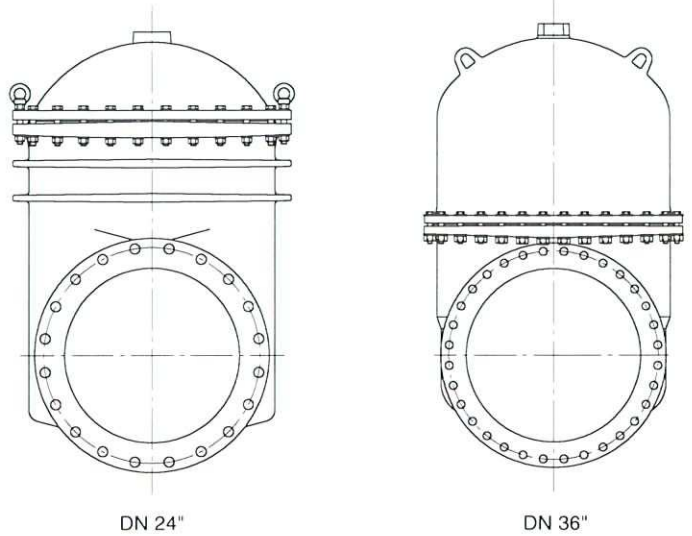

Support wheel

Seguro gate valves can be ordered with a supporting wheel on one side of the gate. This will reduce the stem torque and wear when the valve is placed 'on its side' on a horizontal pipe.

The wheel is made of polyamid, while the other parts are of stainless steel.

Parts list

Pos	Description
51	Wheel bracket
52	Wheel
53	Pin
54	Washer
55	Circlip ring
56	Washer
57	Bolt

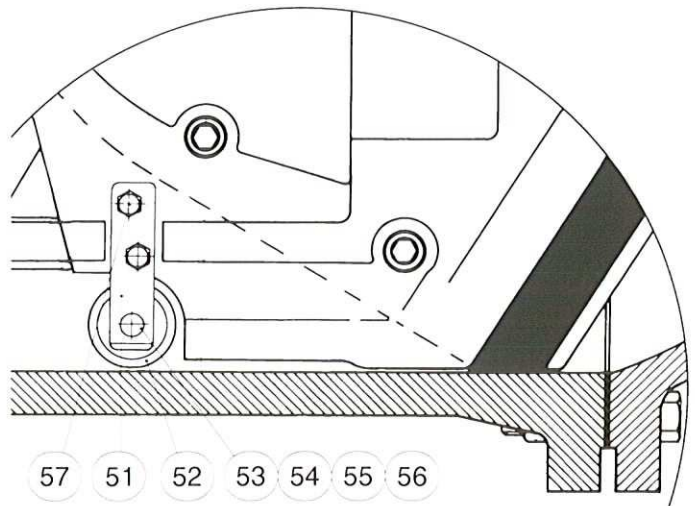

Seguro gate valves are cast, machined, assembled and tested following the best workshop principle and rigid controls. All moving parts are thoroughly lubricated with molybdenum sulphide grease, each valve is coated inside and outside with a special corrosion resisting plastic (polyacrylate/isocyanate) or to the customers specifications. Finally each and every valve is tested to conform to the standards outlined on the specification sheets.

Special designs

In addition to the standard designs shown in this catalogue, we can offer the Seguro gate valves in a number of different layouts to suit your needs.

- **Bypass**
All the valves in standard A, B and TO over DN 16" /DN 400mm can be delivered with bypass mounted either on the side or in the bottom of the valve. The German short style valve (TF) does not leave room for bypass in all sizes.
- **Support wheels**
From DN18" and up, the gate can be supplied with a set of wheels to support the gate and reduce wear, resistance and torque.
- **Chain wheel**
When valves are placed high above the floor, a chain wheel drive is an alternative to the more expensive electrical actuators. Please tell us how long the chain should be (round).
- **Different types of hand wheel**
As standard the Seguro hand wheel is of cast iron, but steel tube hand wheel can be delivered on request. Valves with reduction gear can be delivered with the manufactures standard hand wheel on request.
- **Special materials**
As we manufacture each valve to order we have wide possibilities to use your choice of materials for e.g.:
 - Bolts, standard is hot galvanised external and AISI 304 internal.
 - Stem, standard is AISI 420.
 - Stem nut, standard is brass.
- **Special face to face length**
Our standard face to face length can be seen on the dimension drawings in this catalogue.
- **Special flanges or combinations**
In some cases, valves with two different flanges such as flat face and mechanical joint are required. Please contact us to see the possibilities.
- **Special stem or actuator flange**
The stem and top are basically in two types, either an operating square and a slim bonnet top, or a round stem with a key and a standard flange according to suit the ISO 5211. We have chosen adequate sizes, but if you would like to fit an actuator with another flange, or you need a special flange e.g. for an extended stem, please let us know.
- **Special paint**
As an alternative to our standard paint, we can coat the valves with other systems and colours as well, please let us know of your needs, and we will find a solution to match.

Special services

In addition to the special designs mentioned above, we are also capable of other services related to the manufacture of the Seguro valves.

- **Fitting actuators**
In our program we have a number of different brands and types of actuators, but if you prefer to supply the actuator yourself, we can mount the actuator for you. We that at our workshop, and test the entire system before shipment to your stock or direct to the site.
- **Special tests**
 - Material certificates
 - Special pressure tests
 - Special torque measurements.
- **Packaging**
Please let us know if the transport or storing method requires special packaging of the valve.

After sales service

Nothing lasts forever. We can off course supply you with spare parts for most previously delivered valves.

Accessories

Bypass valve

The installation of a bypass permits the line medium to pass around the main valve in a controlled amount. This is sometimes desirable as it eases operation of the main valve and greatly reduces the risk of damage due to water hammer.

The bypass valve is normally mounted on the side of the main valve with the stems in parallel, but other arrangement can be made on special request. If the main valve is to be mounted with horizontal stem on a horizontal pipeline, the bypass should be placed in the bottom of the valve. Please specify when ordering.

The bypass valve are supplied in the same design as the main valve, that is NRS bypass on a NRS main valve and so on. Unless specially ordered, the bypass valve will be equipped with a hand wheel, or an operating square if the main valve is without hand wheel.

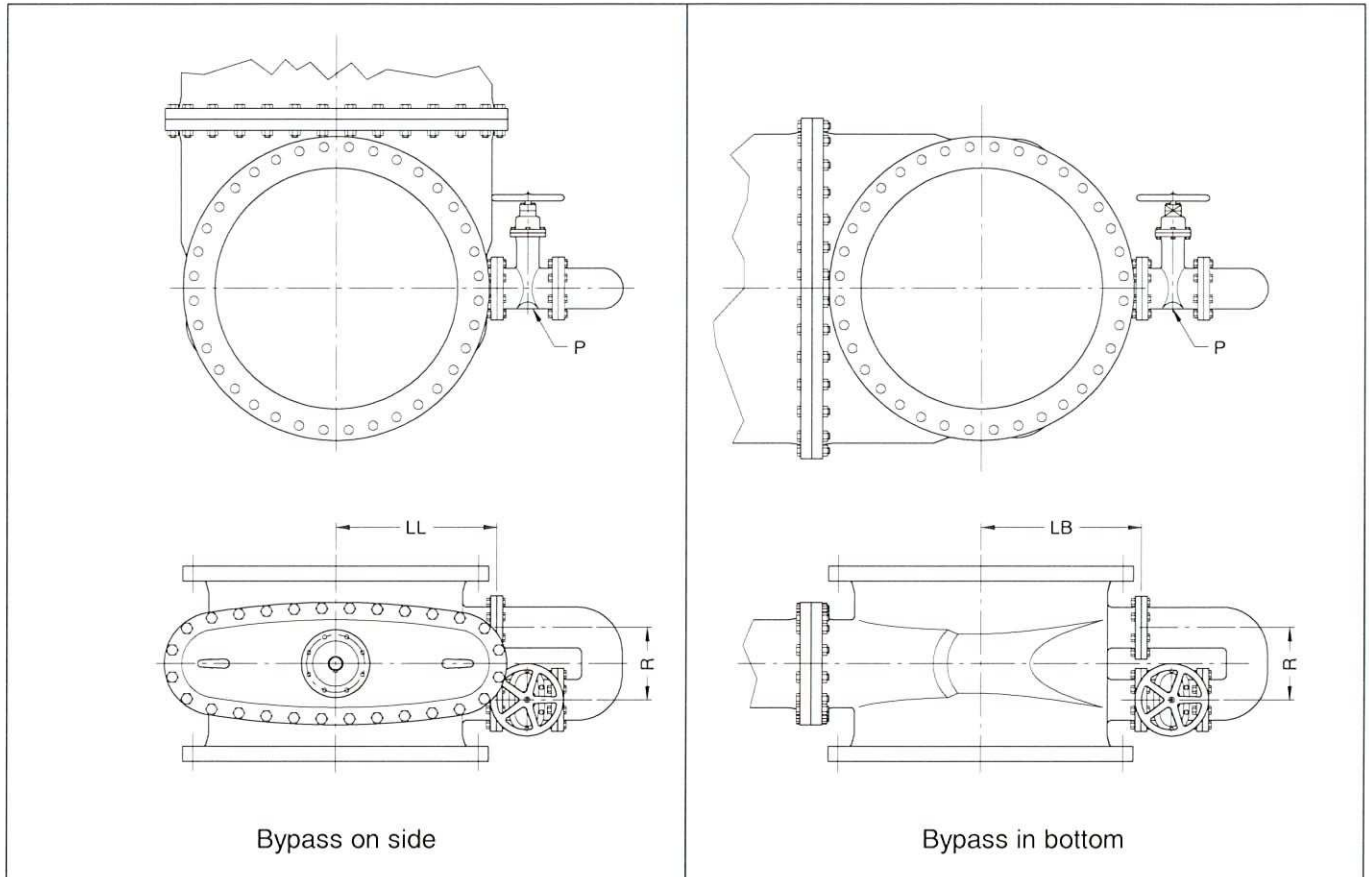

American standard and general measures				
DN	LL	LB	P	R
16"	355	340	3"	205
18"	382	365	3"	205
20"	407	397	3"	205
24"	510	470	4"	240
28"	553			
30"	560	530	4"	240
36"		642	6"	320
42"	708		6"	320
48"				
54"	970		8"	570
60"	1040		8"	640

German standard		
DN	P	R
400		
450	80	205
500	80	205
600	100	240
700	100	240
800	100	240
900		
1000		
1200		
1400		
1500		

Notes: P is the size of the bypass valve.
Missing values have not yet been defined.

Operating Square

Instead of hand wheel, the manual operated valves can be delivered with an protection cap as shown to the right. The table below shows the dimensions for each valve size. Alternatively a 2" operating square (shown in the middle) is available. Both caps are secured by a screw into the stem (to the left).

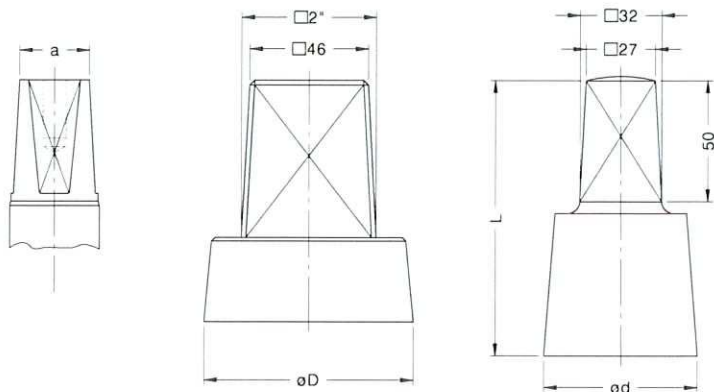

Class 125 / PN 10

DN	Stem	Protection cap	
Inch/mm	a	L	ød
14"/ 350	24,3	106	60
16"/ 400	27,3	114	60
18"/ 450	27,3	114	60
20"/ 500	27,3	114	60
24"/ 600	32,3	124	80
/ 700	32,3	124	80
30"/ 800	36,3	124	100

Revised July 2006

SEGURO

A RUBBER SEALED GATE VALVE

Class 125
Non rising stem
DN 14" - 60"

Class	Max. CWP	Test Pressure	Connections	Operation
125	150 Psi	Shell 230 Psi Seat 150 Psi	Flanges F.F. ASME B 16.1 Face to Face ASME B 16.10	Prepared for Actuator

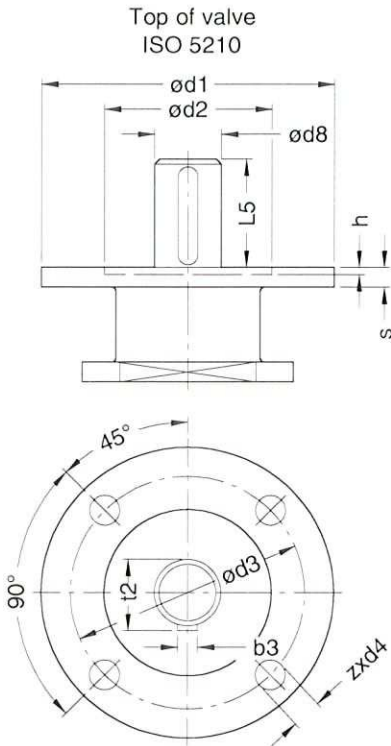

DN	Torque Nm./lbf	No. of turns Open/Close
14"	230 / 170	62
16"	290 / 214	70
18"	340 / 251	78
20"	410 / 302	74
24"	540 / 398	88
30"	830 / 612	102
36"	1000 / 738	106
42"	1165 / 859	117
48"	1580 / 1165	102
54"	2580 / 1903	119
60"	2880 / 2124	135

Approximate operating torque and number of turns direct on stem.
Valid for all class 125 Seguro valves.
The seating torque is up to 10% higher.

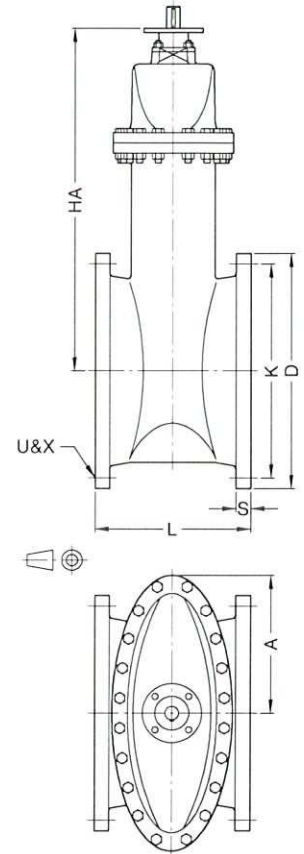

ISO 5210	$\phi d1$	$\phi d2$	$\phi d3$	$\phi d4$	h	s	z
F14	175	100	140	18	4,5	12	4
F16	210	130	165	22	5,5	16	4
F25	300	200	254	18	5,5	16	8
F30	350	230	298	22	5,5	18	8

Materials		
Body	Seal	
Grey Iron	NBR	12-A 1111AL
	EPDM	12-A 1112AL
Ductile Iron	NBR	12-A 1131AL
	EPDM	12-A 1132AL

DN	A	D	HA	K	L	S	U	X	b3	$\phi d8$	L5	t2	ISO 5210
14"	311	533	788	476	381	35,0	12	28,5	8	30	65	33,0	F14
16"	351	597	883	540	406	36,6	16	28,5	10	35	65	38,0	F14
18"	371	635	959	578	432	39,6	16	31,8	10	35	65	38,0	F14
20"	409	699	1019	635	457	42,9	20	31,8	12	40	65	43,0	F14
24"	482	813	1208	749	508	47,8	20	35,0	12	40	80	43,0	F16
30"	592	984	1610	914	*610	53,8	28	35,0	14	50	80	53,5	F16
36"	669	1168	1822	1086	*711	60,5	32	41,1	16	55	110	59,0	F25
42"	761	1346	2235	1257	*864	66,7	36	41,1	18	65	110	65,0	F25
48"	900	1511	2512	1422	*1067	69,9	44	41,1	25	90	110	95,0	F25
54"	970	1683	2858	1594	*1016	76,2	44	50,8	25	90	130	95,0	F30
60"	1067	1864	3103	1759	*1118	79,4	52	50,8	25	90	130	95,0	F30

Notes: * Not included in the standard U = No. of bolts, some of the holes might be threaded on DN 54" and DN 60" X = Size of bolt holes.

All rights reserved
Oct. 2006

BRDR. CHRISTENSEN ApS

Skuderløse - DK 4690 Haslev - Tel. +45 56 36 36 36 - Fax +45 56 36 36 00 - bch@bch.dk - www.bch.dk

page B2

SEGURO

A RUBBER SEALED GATE VALVE

Class 250
Non rising stem
DN 16" - 48"

Class	Max. CWP	Test Pressure	Connections	Operation
250	300 Psi	Shell 450 Psi Seat 300 Psi	Flanges R.F. ASME B 16.1 Face to Face ASME B 16.10	Manual

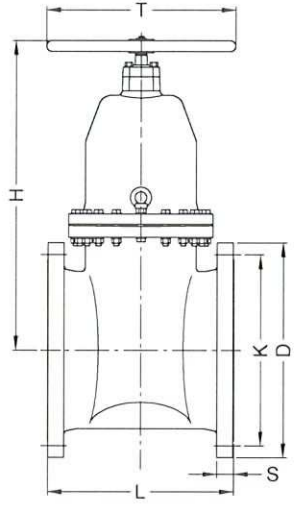
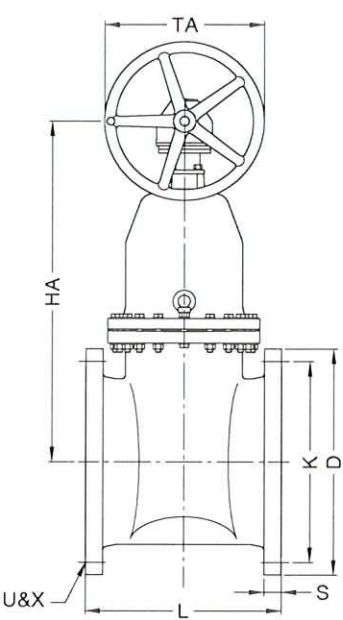
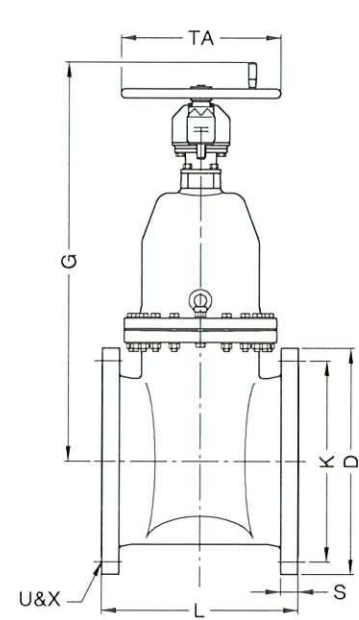
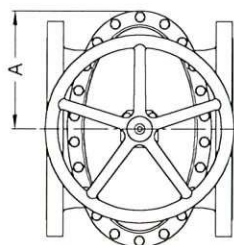
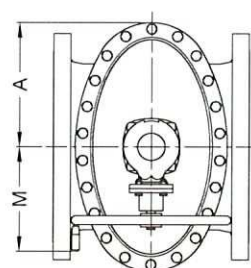
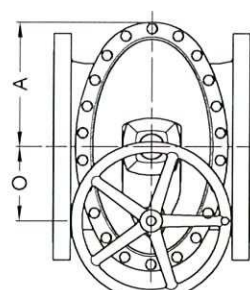
		Stem end			
		with square	w. hand wheel		
					
Materials					
Body	Seal				
Grey Iron	NBR	12-A1311A	12-A1311AH	12-A1311AM	12-A1311AT
	EPDM	12-A1312A	12-A1312AH	12-A1312AM	12-A1312AT
Ductile Iron	NBR	12-A1331A	12-A1331AH	12-A1331AM	12-A1331AT
	EPDM	12-A1332A	12-A1332AH	12-A1332AM	12-A1332AT

The measures E, G, M, O and TA are for valves with AUMA® gearboxes.

DN	A	D	E	G	H	K	L	M	O	S	T	TA	U	X
16"	370	648	997	1194	937	572	610	366	240		500	500		
18"	409	711	1073	1274	1013	629	660	366	240		640	500		
20"	625	775	1138	1838	1078	686	711	366	240		640	500		
24"	503	914	1317	1555	1252	813	787	422	300		720	500		
30"	622	1092	1910	2148		997	914	322	300		800	640		
36"	768	1270	2145	2435		1168	1016	396	360		800	640		
42"	815	1448	2435	2725		1340	1118	396	360		900	720		
48"	900	1651	2636	2926		1543	1219	396	360		1000	720		

Notes: * Not included in the standard U = No. of bolts, some of the holes might be threaded on DN 54" and DN 60" X = Size of bolt holes.

All rights reserved
Oct. 2006

BRDR. CHRISTENSENS HANER A/S

Skuderløse - DK 4690 Haslev - Tel. +45 56 36 36 36 - Fax +45 56 36 36 00 - bch@bch.dk - www.bch.dk

page B7

SEGURO

A RUBBER SEALED GATE VALVE

Class 250
Non rising stem
DN 16" - 48"

Class	Max. CWP	Test Pressure	Connections	Operation
125	150 Psi	Shell 230 Psi Seat 150 Psi	Flanges F.F. ASME B 16.1 Face to Face ASME B 16.10	Prepared for Actuator

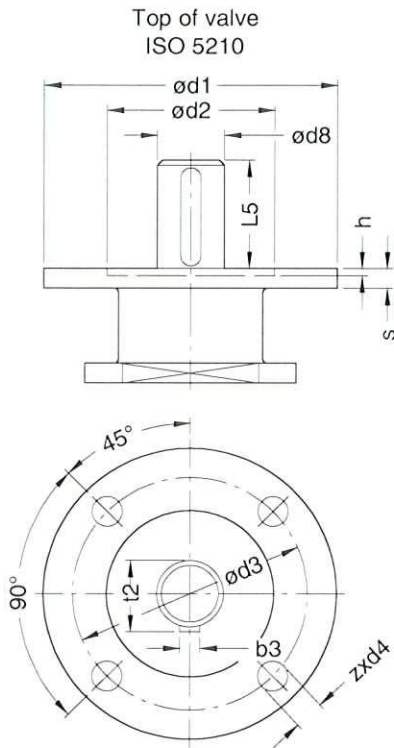

DN	Torque Nm./lbf	No. of turns Open/Close
14"		62
16"		70
18"		78
20"		74
24"		88
30"		102
36"		106
42"		117
48"		102
54"		119
60"		135

Approximate operating torque and number of turns direct on stem.
Valid for all class 250 Seguro valves.
The seating torque is up to 10% higher.

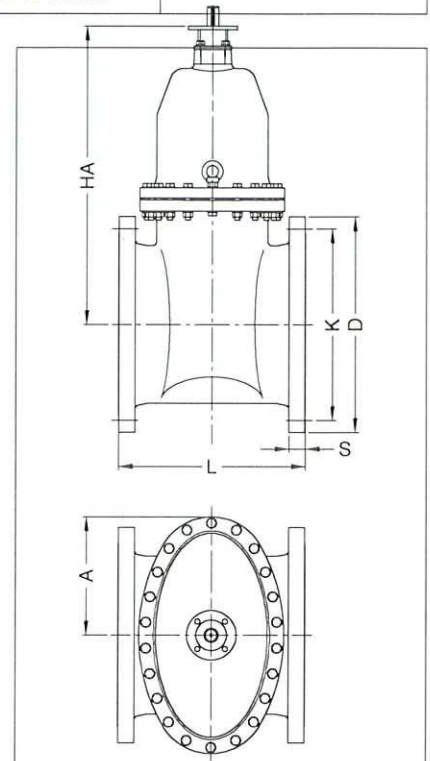

ISO 5210	$\phi d1$	$\phi d2$	$\phi d3$	$\phi d4$	h	s	z	Materials		
								Body	Seal	
F14	175	100	140	18	4,5	12	4	Grey	NBR	12-A1311AL
F16	210	130	165	22	5,5	16	4	Iron	EPDM	12-A1312AL
F25	300	200	254	18	5,5	16	8	Ductile	NBR	12-A1331AL
F30	350	230	298	22	5,5	18	8	Iron	EPDM	12-A1332AL

Body and bonnet material: Grey: Cast Iron ASTM A 126 Class B, Ductile: Ductile Iron ASTM A536 GR 60-40-18.

DN	A	D	HA	K	L	S	U	X	b3	$\phi d8$	L5	t2	ISO 5210
14"			788										F14
16"			883										F14
18"			959										
20"			1019										
24"			1208										F16
30"			1610										
36"			1822										F25
42"			2235										
48"	900	1511	2512	1422	*1067	69,9	44	41,1	25	90	110	95,0	
54"	970	1683	2858	1594	*1016	76,2	44	50,8	25	90	130	95,0	F30
60"	1067	1864	3103	1759	*1118	79,4	52	50,8	25	90	130	95,0	F30

Notes: * Not included in the standard U = No. of bolts, some of the holes might be threaded on DN 54" and DN 60" X = Size of bolt holes.

BRDR. CHRISTENSENS HANER A/S

Skuderløse - DK 4690 Haslev - Tel. +45 56 36 36 36 - Fax +45 56 36 36 00 - bch@bch.dk - www.bch.dk

page B8

SEGURO

A RUBBER SEALED GATE VALVE

Class 250
Non rising stem
DN 16" - 48"

All rights reserved
Oct 2006

SEGURO

A RUBBER SEALED GATE VALVE

PN 10
Non rising stem
DN 350 – DN 1400

Class	Max. CWP	Test Pressure	Connections	Operation
PN 10	1000 kPa	Shell 1600 kPa Seat 1000 kPa	Flanges R.F. EN 1092-2 table 8 Face to Face EN 558-1 table1 c14	Manual

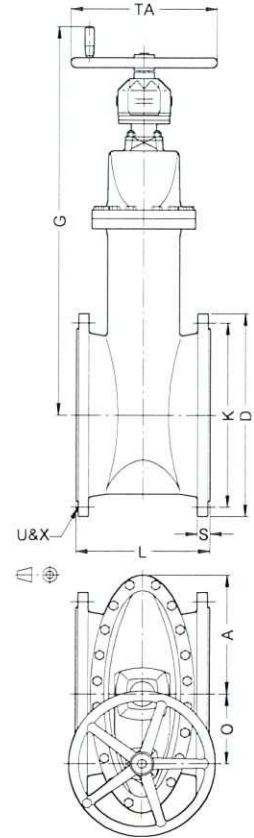
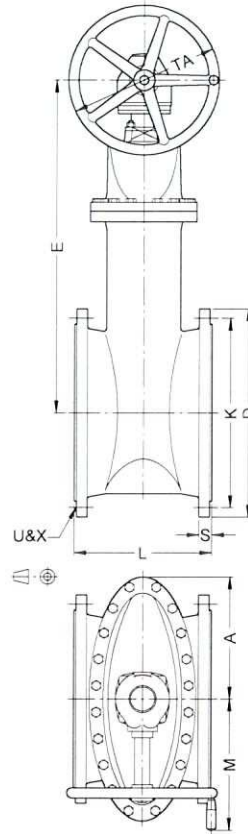
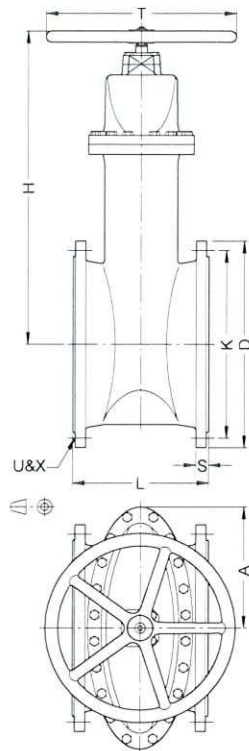

Materials		Stem end			
Body	Seal	with square	w. hand wheel	Bevel gear and hand wheel	Spur gear and hand wheel
Grey Iron	NBR	12-TF 1111A	12-TF 1111AH	12-TF 1111AM	12-TF 1111AT
	EPDM	12-TF 1112A	12-TF 1112AH	12-TF 1112AM	12-TF 1112AT
Ductile Iron	NBR	12-TF 1131A	12-TF 1131AH	12-TF 1131AM	12-TF 1131AT
	EPDM	12-TF 1132A	12-TF 1132AH	12-TF 1132AM	12-TF 1132AT

The measures E, G, M, O and TA are for valves with AUMA® gearboxes.

DN	A	D	E	G	H	K	L	M	O	S	T	TA	U	UU	X	XX
350	311	505	888	1109	820	460	290	366	240	30	500	400	16	-	23	M20
400	351	565	973	1194	919	515	310	366	240	32	500	400	16	2	28	M24
450	371	615	1059	1277	1000	565	330	366	240	32	640	400	20	-	28	M24
500	409	670	1119	1340	1067	620	350	366	240	34	640	500	20	-	28	M24
600	482	780	1321	1555	1253	725	390	439	300	36	720	500	20	2	31	M27
700	506	895	1484	1721	1456	840	430	439	300	40	720	500	24	-	31	M27
800	592	1015	1723	1958	1654	950	470	439	300	44	800	640	24	4	34	M30
900	669	1115	1950	2226		1050	560*	454	360	46		640	28	-	34	M30
1000	761	1230	2363	2639		1160	550	454	360	50		720	28	4	37	M33
1200	900	1455	2640	2914		1380	1070*	454	360	56		720	32	-	41	M36
1400	970	1675	3041	3268		1590	1016*	558	380	62		800	36	4	44	M39
1600	1069	1915	3195	3250		1820	1118	626	380	68		800	40	4	50	M45

Notes: * Not included in the standard. U = No. Of bolts. UU = No. of threaded holes.

X = Size of bolt holes. XX = Size of threaded holes.

Values for operating torque (on stem) and number of revolutions can be found on page C2.

All rights reserved
Juli 2009

BRDR. CHRISTENSEN ApS

Skuderløse - DK 4690 Haslev - Tel. +45 56 36 36 36 - Fax +45 56 36 36 00 - bch@bch.dk - www.bch.dk

page C1

SEGURO

A RUBBER SEALED GATE VALVE

PN 10
Non rising stem
DN 350 – DN 1400

Class	Max. CWP	Test Pressure	Connections	Operation
PN 10	1000 kPa	Shell 1600 kPa Seat 1000 kPa	Flanges R.F. EN 1092-2 table 8 Face to Face EN 558-1 table1 c14	Prepared for Actuator

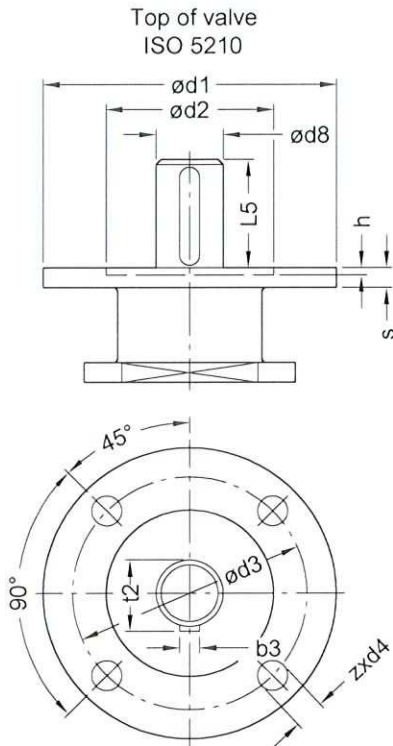

DN	Torque Nm.	No. of turns Open/Close
350	230	62
400	290	70
450	340	78
500	410	74
600	540	88
700	670	103
800	830	102
900	1000	106
1000	1165	117
1200	1580	102
1400	2580	119

Approximate operating torque and number of turns direct on stem.
Valid for all PN 10 Seguro valves.
The seating torque is up to 10% higher.

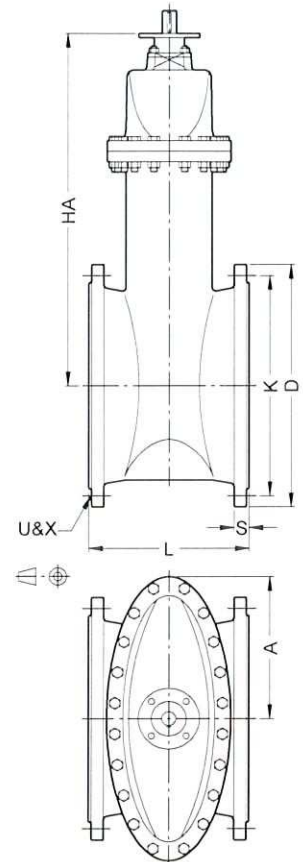

ISO 5210	$\varnothing d1$	$\varnothing d2$	$\varnothing d3$	$\varnothing d4$	h	s	z
F14	175	100	140	18	4,5	12	4
F16	210	130	165	22	5,5	16	4
F25	300	200	254	18	5,5	16	8
F30	350	230	298	22	5,5	18	8

Materials		
Body	Seal	
Grey Iron	NBR	12-TF 1111AL
	EPDM	12-TF 1112AL
Ductile Iron	NBR	12-TF 1131AL
	EPDM	12-TF 1132AL

DN	A	D	HA	K	L	S	U	UU	X	XX	b3	$\varnothing d8$	L5	t2	ISO 5210
350	311	505	788	460	290	30	16	–	23	M20	8	30	65	33,0	F14
400	351	565	883	515	310	32	16	2	28	M24	10	35	65	38,0	F14
450	371	615	959	565	330	32	20	–	28	M24	10	35	65	38,0	F14
500	409	670	1019	620	350	34	20	–	28	M24	12	40	65	43,0	F14
600	482	780	1208	725	390	36	20	2	31	M27	12	40	80	43,0	F16
700	506	895	1371	840	430	40	24	–	31	M27	12	40	80	42,0	F16
800	592	1015	1610	950	470	44	24	4	34	M30	14	50	80	53,5	F16
900	669	1115	1822	1050	560*	46	28	–	34	M30	16	55	110	59,0	F25
1000	761	1230	2235	1160	550	50	28	4	37	M33	18	65	110	65,0	F25
1200	900	1455	2512	1380	1070*	56	32	–	41	M36	25	90	110	95,0	F25
1400	970	1675	2858	1590	1016*	62	36	4	44	M39	25	90	130	95,0	F30

Notes: * Not included in the standard. U = No. Of bolts. UU = No. of threaded holes.
X = Size of bolt holes. XX = Size of threaded holes.

All rights reserved
Sep. 2006

BRDR. CHRISTENSEN ApS

Skudersløse - DK 4690 Haslev - Tel. +45 56 36 36 36 - Fax +45 56 36 36 00 – bch@bch.dk – www.bch.dk

page C2

SEGURO

A RUBBER SEALED GATE VALVE

PN 16
Non rising stem
DN 350 – DN 1400

Class	Max. CWP	Test Pressure	Connections	Operation
PN 16	1600 kPa	Shell 2500 kPa Seat 1600 kPa	Flanges R.F. EN 1092-2 table 9 Face to Face EN 558-1 table1 c14	Manual

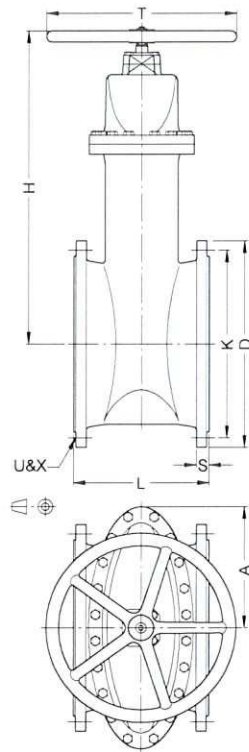

Stem end

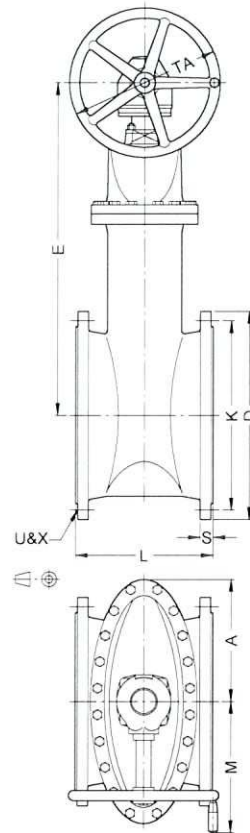

Bevel gear and hand wheel

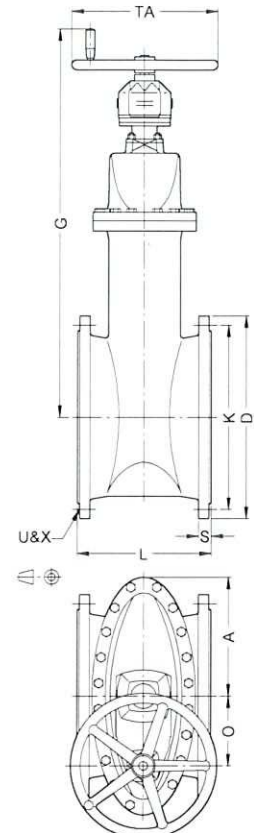

Spur gear and hand wheel

Materials		Stem end			
Body	Seal	with square	w. hand wheel	Bevel gear and hand wheel	Spur gear and hand wheel
Grey Iron	NBR	12-TF 1211A	12-TF 1211AH	12-TF 1211AM	12-TF 1211AT
	EPDM	12-TF 1212A	12-TF 1212AH	12-TF 1212AM	12-TF 1212AT
Ductile Iron	NBR	12-TF 1231A	12-TF 1231AH	12-TF 1231AM	12-TF 1231AT
	EPDM	12-TF 1232A	12-TF 1232AH	12-TF 1232AM	12-TF 1232AT

The measures E, G, M, O and TA are for valves with AUMA® gearboxes.

DN	A	D	E	G	H	K	L	M	O	S	T	TA	U	UU	X	XX
350	311	520	888	1109	820	470	290	366	240	36	500	400	16	4	28	M24
400	351	580	973	1194	919	525	310	366	240	38	500	400	16	4	31	M27
450	371	640	1059	1277	1000	585	330	366	240	40	640	400	20	4	31	M27
500	409	715	1119	1340	1067	650	350	366	240	42	640	500	20	4	34	M30
600	482	840	1321	1555	1253	770	390	439	300	48	720	500	20	6	37	M33
700	506	910	1484	1721	1456	840	430	439	300	54	720	500	24	6	37	M33
800	592	1025	1723	2050	1654	950	610*	439	300	58	800	640	24	-	41	M36
900	669	1125	1950	2226		1050	711*	454	360	62		640	28	-	41	M36
1000	761	1255	2363	2639		1170	864*	454	360	66		720	28	-	44	M39
1200	900	1485	2640	2914		1390	1070*	454	360	76*		720	32	-	50	M45
1400	970	1685	3041	3268		1590	1016*	558	380	82*		800	36	4	50	M45

Notes: * Not included in the standard. U = No. Of bolts. UU = No. of threaded holes.

X = Size of bolt holes. XX = Size of threaded holes.

Values for operating torque (on stem) and number of revolutions can be found on page C6

All rights reserved
Sep. 2006

BRDR. CHRISTENSEN ApS

Skudersløse - DK 4690 Haslev - Tel. +45 56 36 36 36 - Fax +45 56 36 36 00 - bch@bch.dk - www.bch.dk

page C5

SEGURO

A RUBBER SEALED GATE VALVE

PN 16
Non rising stem
DN 350 – DN 1400

Class	Max. CWP	Test Pressure	Connections	Operation
PN 16	1600 kPa	Shell 2500 kPa Seat 1600 kPa	Flanges R.F. EN 1092-2 table 9 Face to Face EN 558-1 table1 c14	Prepared for Actuator

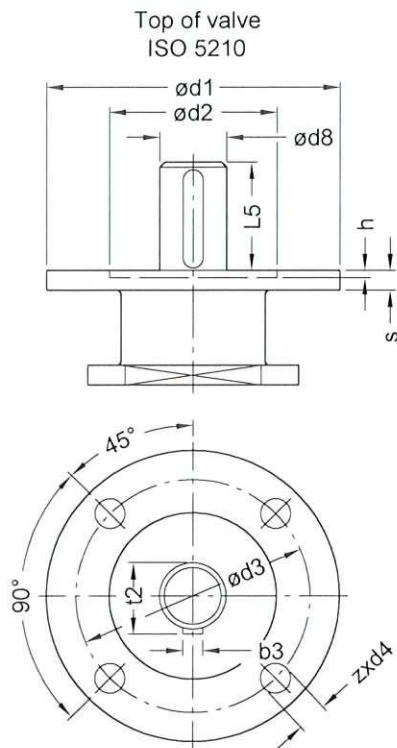

DN	Torque Nm.	No. of turns Open/Close
350	253	62
400	319	70
450	374	78
500	451	74
600	594	88
700	737	103
800	913	102
900	1100	103
1000	1282	117
1200	1738	102
1400	2840	119

Approximate operating torque and number of turns direct on stem.
Valid for all PN 16 Seguro valves.
The seating torque is 10% higher.

ISO 5210	$\varnothing d1$	$\varnothing d2$	$\varnothing d3$	$\varnothing d4$	h	s	z
F14	175	100	140	18	4,5	12	4
F16	210	130	165	22	5,5	16	4
F25	300	200	254	18	5,5	18	8
F30	350	230	298	22	5,5	18	8

Materials		
Body	Seal	
Grey Iron	NBR	12-TF 1111AL
	EPDM	12-TF 1112AL
Ductile Iron	NBR	12-TF 1131AL
	EPDM	12-TF 1132AL

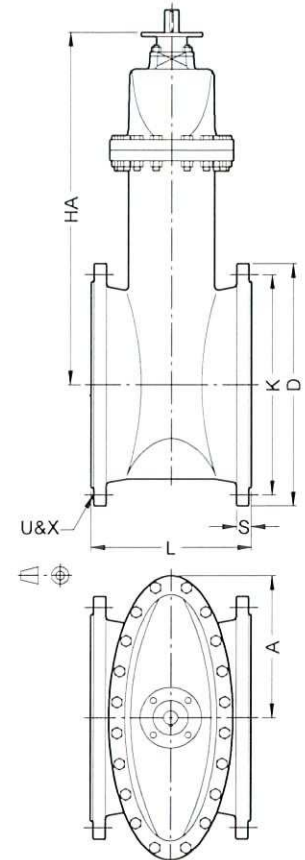

DN	A	D	HA	K	L	S	U	UU	X	XX	b3	$\varnothing d8$	L5	t2	ISO 5210
350	311	520	788	470	290	36	16	4	28	M24	8	30	65	33,0	F14
400	351	580	873	525	310	38	16	4	31	M27	10	35	65	38,0	F14
450	371	640	956	585	330	40	20	4	31	M27	10	35	65	38,0	F14
500	409	715	1019	650	350	42	20	4	34	M30	12	40	65	43,0	F14
600	482	840	1208	770	390	48	20	6	37	M33	12	40	80	43,0	F16
700	506	910	1374	840	430	54	24	6	37	M33	12	40	80	42,0	F16
800	592	1025	1610	950	610*	58	24	-	41	M36	14	50	80	53,5	F16
900	669	1125	1822	1050	711*	62	28	-	41	M36	16	55	110	59,0	F25
1000	761	1255	2235	1170	864*	66	28	-	44	M39	18	65	110	65,0	F25
1200	900	1485	2510	1390	1070*	76*	32	-	50	M45	25	90	110	95,0	F25
1400	970	1685	2858	1590	1016*	82*	36	4	50	M45	25	90	130	95,0	F30

Notes: * Not included in the standard. U = No. Of bolts. UU = No. of threaded holes.
X = Size of bolt holes. XX = Size of threaded holes.

All rights reserved
Sep. 2006

BRDR. CHRISTENSEN ApS

Skudersløse - DK 4690 Haslev - Tel. +45 56 36 36 36 - Fax +45 56 36 36 00 - bch@bch.dk - www.bch.dk

page C6

Sectional view and parts list

Non rising stem with hand wheel (AH).

Class 125: DN 14" – DN 30"

Class 250: DN 14" – DN 28"

PN 10: DN 350 – DN 800

PN 25: DN 350 – DN 700

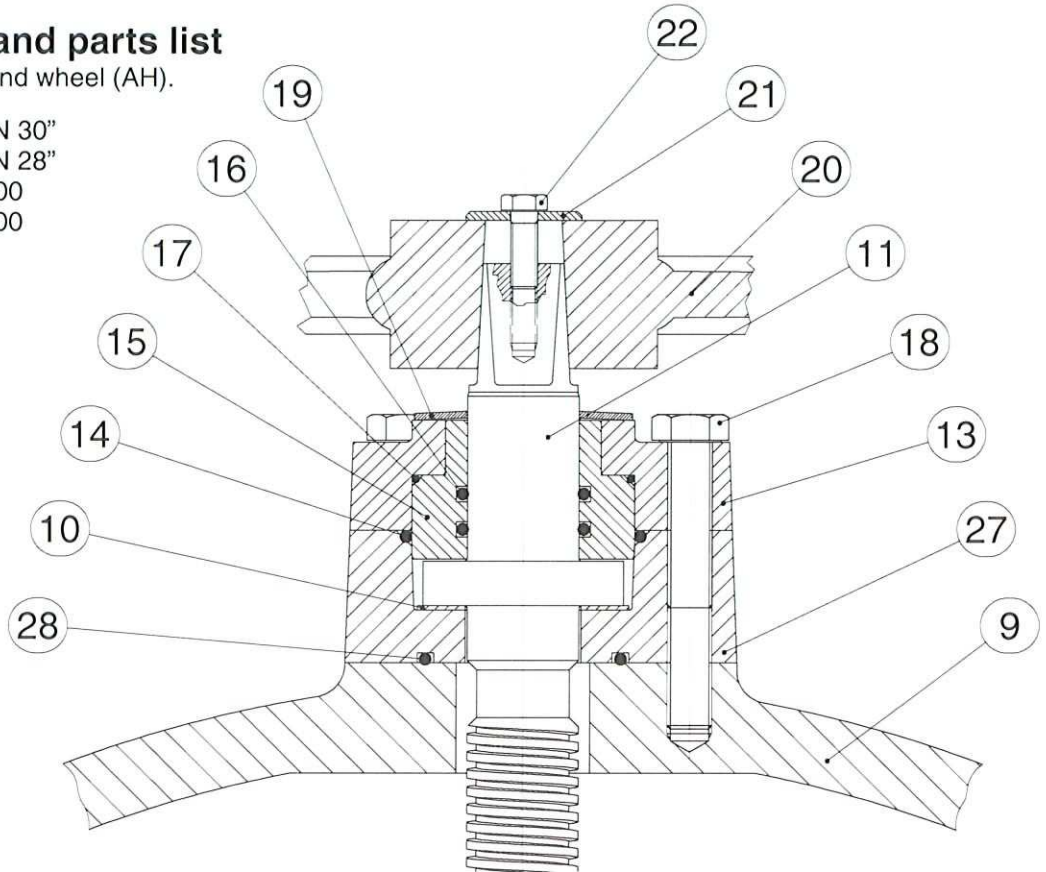

Pos. Description

- 1 Body
- 2 Wedge (gate)
- 3 Rubber seal
- 4 Washer
- 5 Screw
- 6 Pressure piece
- 7 Stem nut
- 8 Gasket
- 9 Bonnet
- 10 Washer (bearing)
- 11 Stem
- 12 Bolt
- 13 O-ring piece
- 14 O-ring
- 15 Bushing
- 16 O-ring
- 17 O-ring
- 18 Bolt
- 19 Weather seal
- 20 Handwheel or operating square
- 21 Washer
- 22 Screw
- 23 Nut
- 24 Washer (not shown)
- 25 Stud for ring nut (not shown)
- 26 Ring nut (not shown)
- 27 Stem guide*
- 28 O-ring*
- 29 Relieve plug (not shown)

* DN 800 / 30" and DN 900 / 36" only

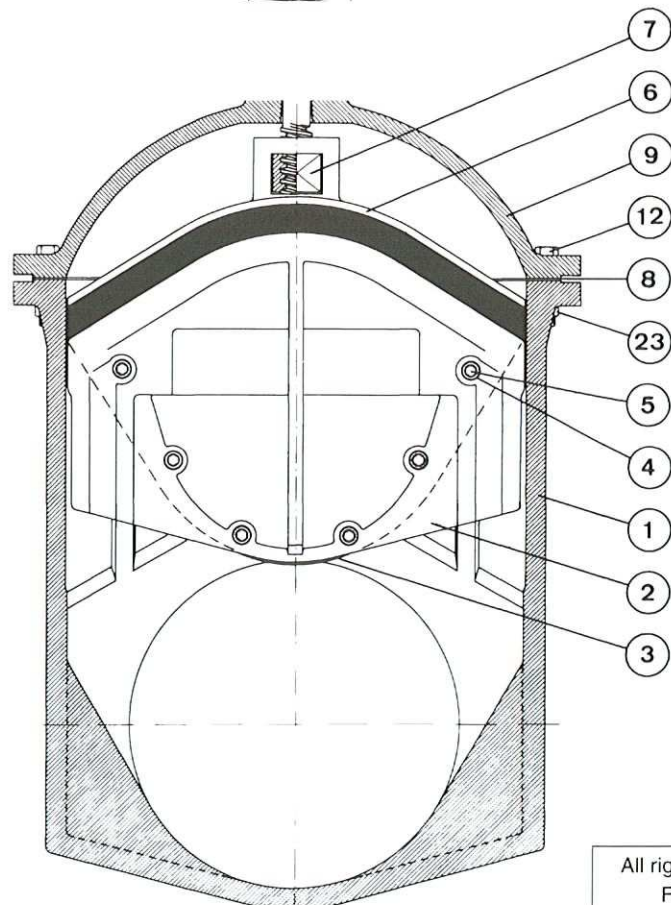

All rights reserved
Feb 2006

Sectional view and parts list

With non rising stem and actuator flange (AL).

Class 125: DN 14" – DN 36"

Class 250: DN 14" – DN 28"

PN 10: DN 350 – DN 900

PN 25: DN 350 – DN 700

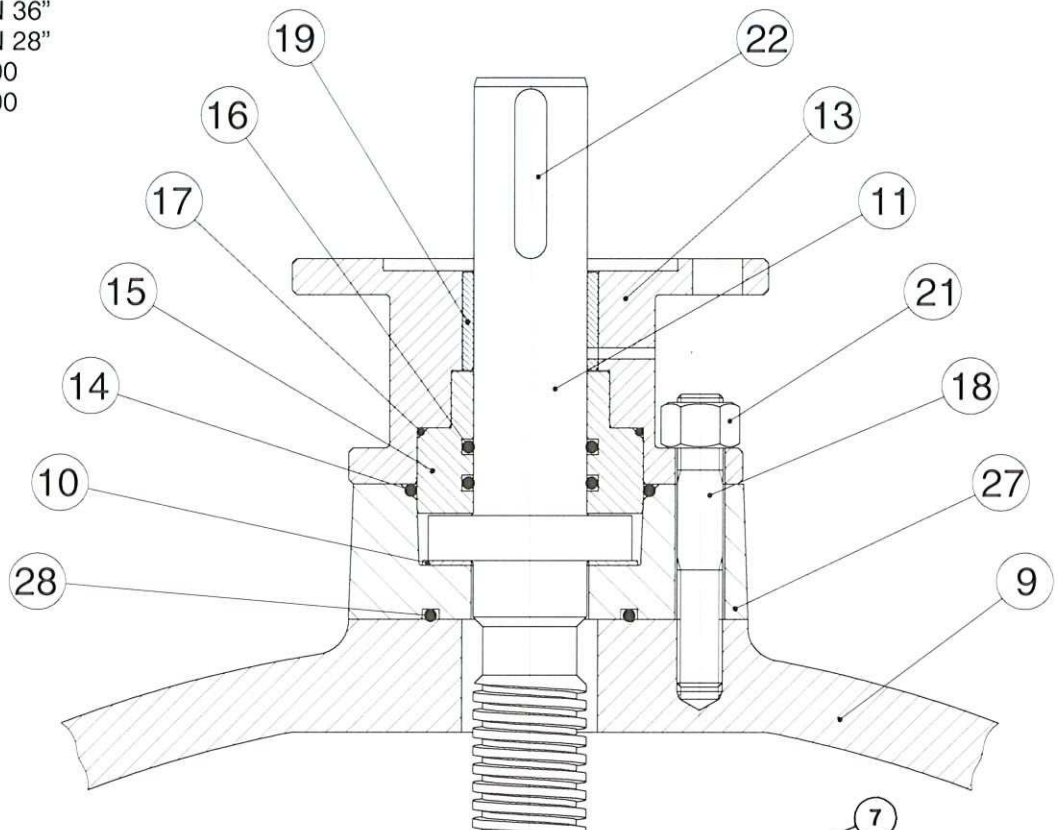

Pos. Description

- 1 Body
- 2 Wedge (gate)
- 3 Rubber seal
- 4 Washer
- 5 Screw
- 6 Pressure piece
- 7 Stem nut
- 8 Gasket
- 9 Bonnet
- 10 Washer (bearing)
- 11 Stem
- 12 Bolt
- 13 O-ring piece with ISO 5210 flange
- 14 O-ring
- 15 Bushing
- 16 O-ring
- 17 O-ring
- 18 Stud
- 19 Bushing*
- 21 Nut
- 22 Key
- 23 Nut
- 24 Washer (not shown)
- 25 Stud for ring nut (not shown)
- 26 Ring nut (not shown)
- 27 Stem guide*
- 28 O-ring*
- 29 Relieve plug (not shown)

* DN 800 / 30" and DN 900 / 36" only

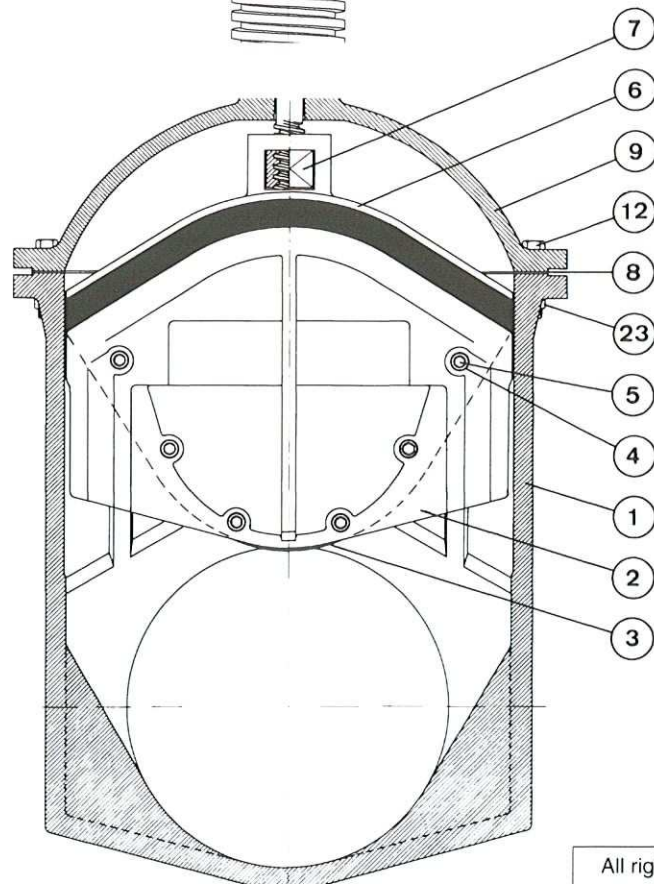

All rights reserved
Feb 2006

Sectional view and parts list

With non rising stem and actuator flange (AL).

Class 125: DN 42" – DN 60"

Class 250: DN 30" – DN 60"

PN 10: DN 1000 – DN 1500

PN 25: DN 800 – DN 1500

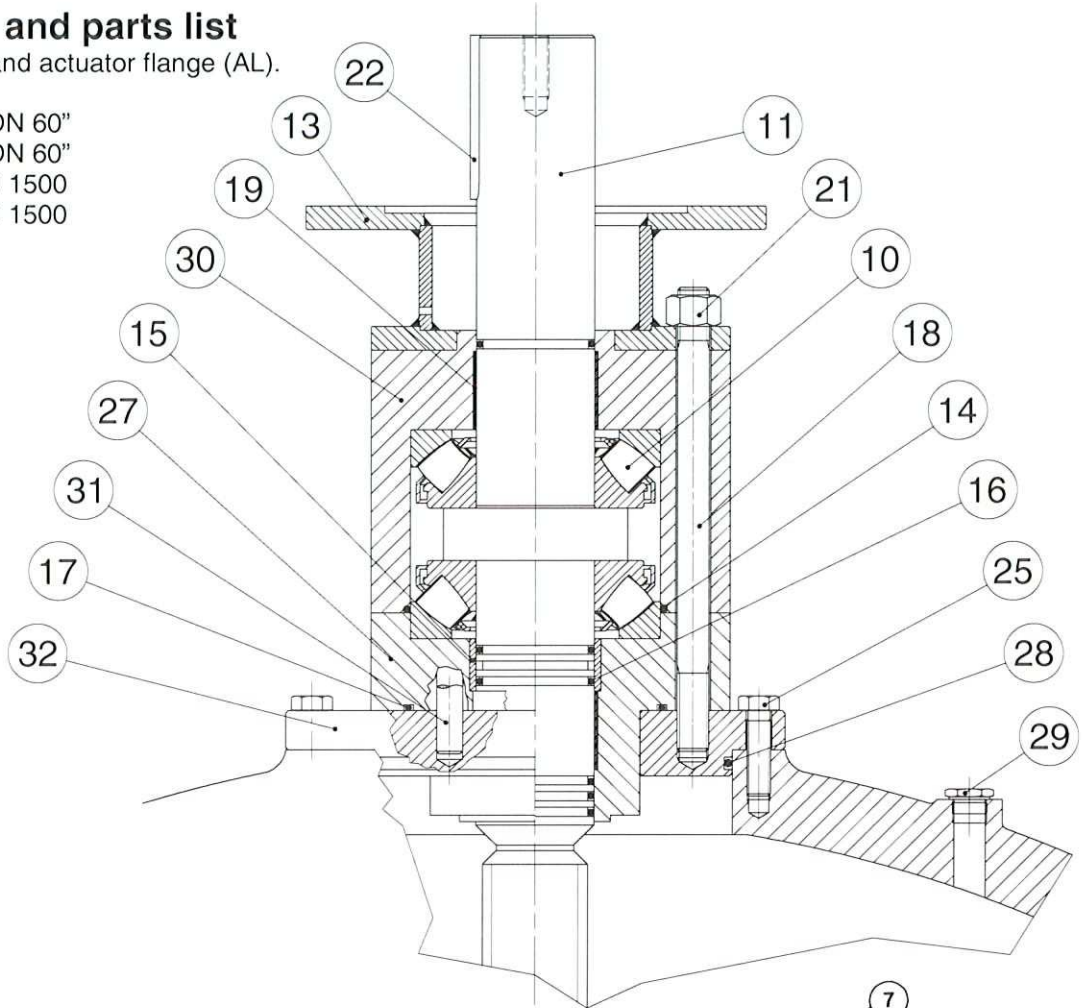

Pos. Description

- 1 Body
- 2 Wedge (gate)
- 3 Rubber seal
- 4 Washer
- 5 Screw
- 6 Pressure piece
- 7 Stem nut
- 8 Gasket
- 9 Bonnet
- 10 Roller bearing
- 11 Stem
- 12 Bolt
- 13 Top flange
- 14 O-ring
- 15 Bushing
- 16 O-ring
- 17 O-ring
- 18 Stud
- 19 Bearing
- 21 Nut
- 22 Key
- 23 Nut
- 24 Washer at pos. 32 (not shown)
- 25 Screw
- 27 Stem guide
- 28 O-ring*
- 29 Relieve plug (some designs only)
- 30 Bearing housing
- 31 Dowel pin
- 32 Bonnet cover*
- 33 Grease nipple (not shown)

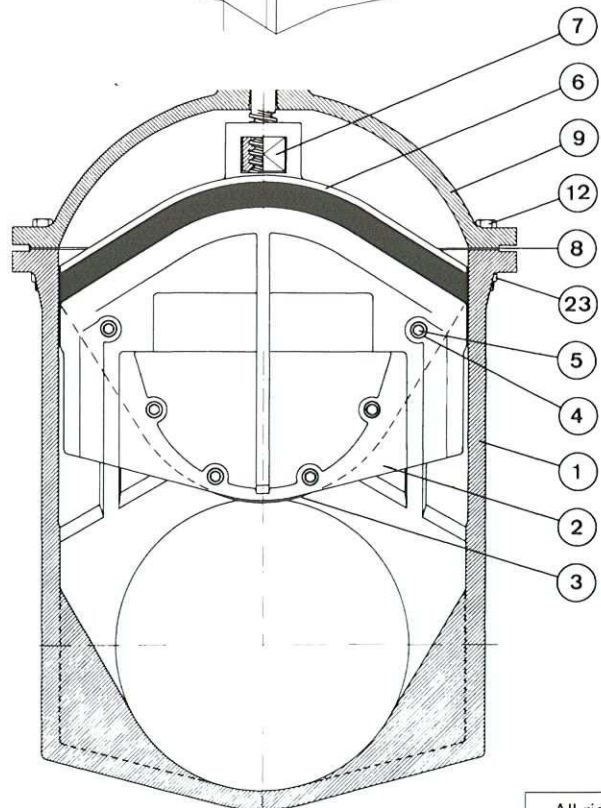

* DN 1400 / 54" and DN 1500 / 60" only

Sectional view and parts list

With outside stem, yoke and hand wheel (BH).

All rights reserved
April 2006

Class 125: DN 14" – DN 36"
 Class 250: DN 14" – DN 28"
 PN 10: DN 350 – DN 900
 PN 25: DN 350 – DN 700

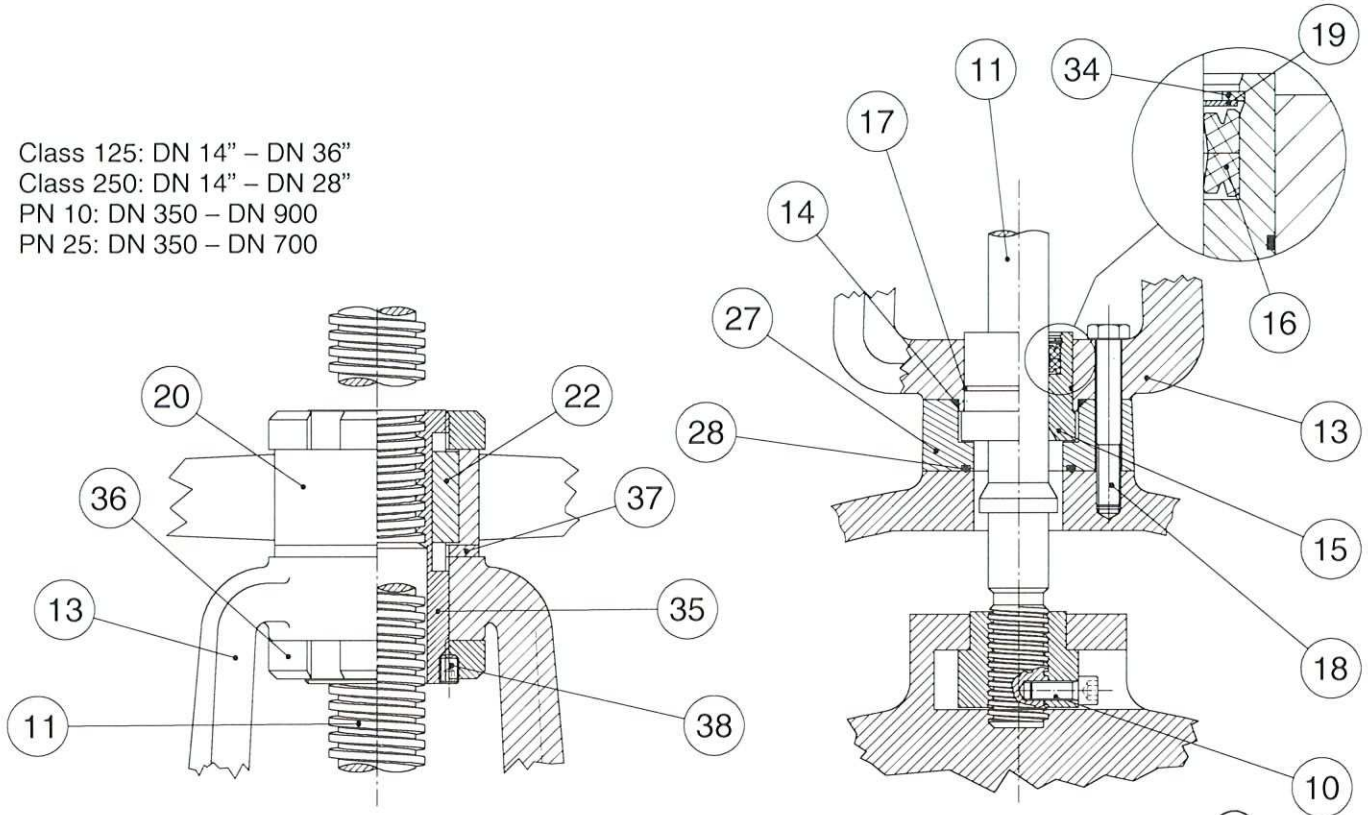

Pos. Description

- 1 Body
- 2 Wedge (gate)
- 3 Rubber seal
- 4 Washer
- 5 Screw
- 6 Pressure piece
- 7 Stem nut
- 8 Gasket
- 9 Bonnet
- 10 Screw
- 11 Stem
- 12 Bolt
- 13 Yoke
- 14 O-ring
- 15 Bushing
- 16 U-cup seal
- 17 O-ring
- 18 Bolt
- 19 Washer
- 20 Hand wheel
- 22 Key
- 23 Nut
- 24 Washer (not shown)
- 25 Stud for ring nut (not shown)
- 26 Ring nut (not shown)
- 27 Stem guide*
- 28 O-ring*
- 29 Relieve plug (not shown)
- 34 Snap ring
- 35 Top stem nut
- 36 Nut
- 37 Bearing ring
- 38 Socket set screw

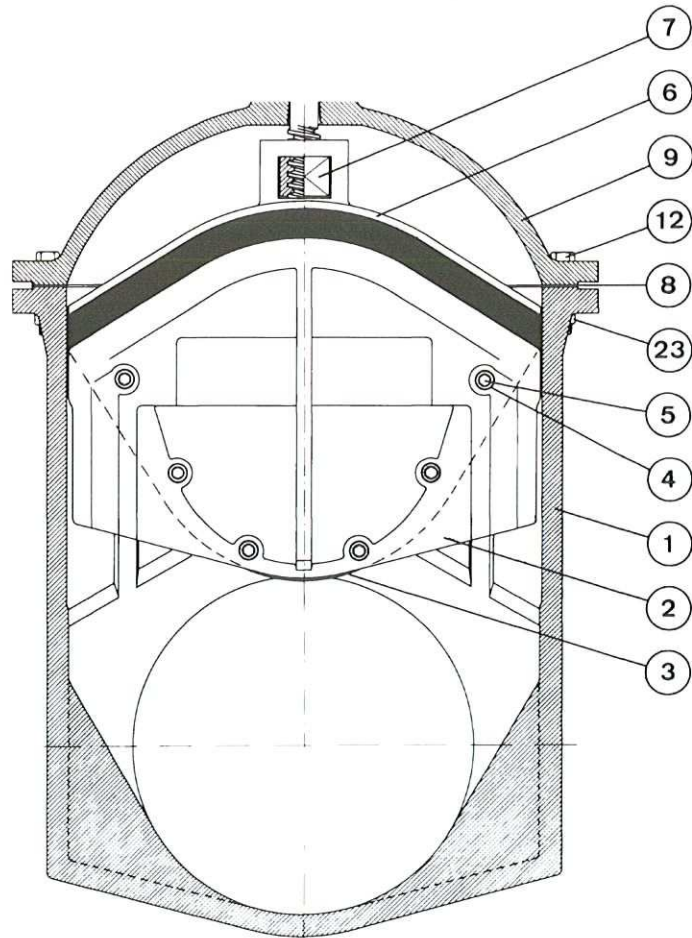

* DN 800 / 30" and DN 900 / 36" only.

All rights reserved
 April 2006

SEGURO

A RUBBER SEALED GATE VALVE

Class 125
Non rising stem
DN 14" - 60"

Class	Max. CWP	Test Pressure	Connections	Operation
125	150 Psi	Shell 230 Psi Seat 150 Psi	Flanges F.F. ASME B 16.1 Face to Face ASME B 16.10	Manual

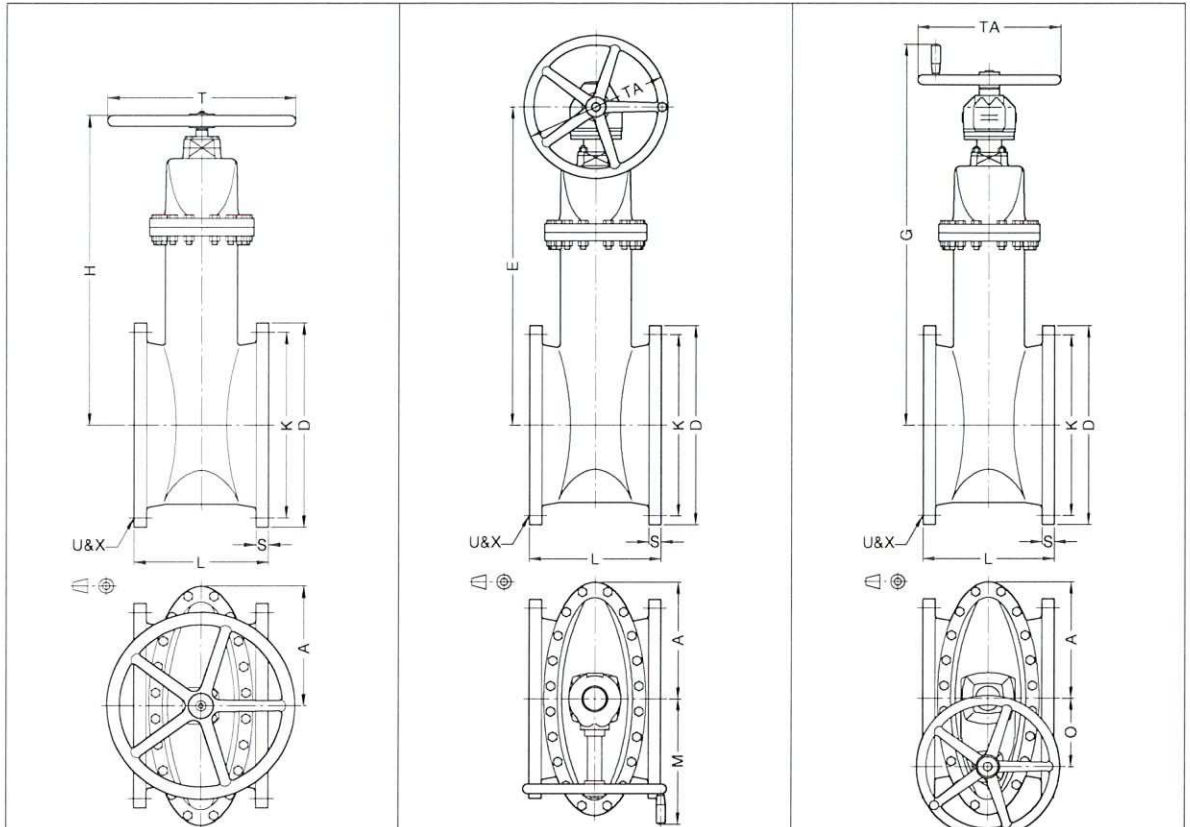

Materials		Stem end		Bevel gear and hand wheel	Spur gear and hand wheel
Body	Seal	with square	w. hand wheel		
Grey Iron	NBR	12-A1111A	12-A1111AH	12-A1111AM	12-A1111AT
	EPDM	12-A1112A	12-A1112AH	12-A1112AM	12-A1112AT
Ductile Iron	NBR	12-A1131A	12-A1131AH	12-A1131AM	12-A1131AT
	EPDM	12-A1132A	12-A1132AH	12-A1112AM	12-A1132AT

The measures E, G, M, O and TA are for valves with AUMA® gearboxes.

DN	A	D	E	G	H	K	L	M	O	S	T	TA	U	X
14"	311	533	888	1109	820	476	381	366	240	35,0	500	400	12	28,5
16"	351	597	973	1194	919	540	406	366	240	36,6	500	400	16	28,5
18"	371	635	1059	1277	1000	578	432	366	240	39,6	640	400	16	31,8
20"	409	699	1119	1340	1067	635	457	366	240	42,9	640	500	20	31,8
24"	482	813	1321	1555	1253	749	508	439	300	47,8	720	500	20	35
30"	592	984	1723	1958	1654	914	*610	439	300	53,8	800	640	28	35
36"	669	1168	1950	2226		1086	*711	454	360	60,5	800	640	32	41,1
42"	761	1346	2363	2639		1257	*864	454	360	66,7	900	720	36	41,1
48"	900	1511	2640	2914		1422	*1067	454	360	69,9	1000	720	44	41,1
54"	970	1683	3041	3268		1594	*1016	558	380	76,2		800	44	50,8
60"	1067	1864	3286	3531		1759	*1118	558	380	79,4		800	52	50,8

Notes: * Not included in the standard U = No. of bolts, some of the holes might be threaded on DN 54" and DN 60" X = Size of bolt holes.

All rights reserved
Oct. 2006

BRDR. CHRISTENSEN ApS

Skuderløse - DK 4690 Haslev - Tel. +45 56 36 36 36 - Fax +45 56 36 36 00 - bch@bch.dk - www.bch.dk

page B1